

BALDOR® • RELIANCE 

Product Information Packet

D5015RS-BV

15HP,1750RPM,DC,2113ATZ,DPG-FV,

Part Detail							
Revision:	-	Status:	PRD/A	Change #:		Proprietary:	No
Type:	DC	Prod. Type:		Elec. Spec:	G7895A A	CD Diagram:	406770-001
Enclosure:	DP	Mfg Plant:		Mech. Spec:		Layout:	609952-096
Frame:	SC211	Mounting:	F1	Poles:	00	Created Date:	04-09-2015
Base:		Rotation:	R	Insulation:	F	Eff. Date:	04-13-2015
Field Type:		Literature:		Elec. Diagram:		Replaced By:	

Specs			
Enclosure:	DP		
Frame:	SC2113ATZ		
Frame Material:	Steel		
Agency Approvals:	CCSA US		
Base Indicator:	Rigid		
Bearing Grease Type:	Polyrex EM (-20F +300F)		
Drip Cover:	No Drip Cover		
Duty Rating:	CONT		
Feedback Device:	NO FEEDBACK		
Field Winding Type:	STAB SHUNT		
Frame Prefix:	SC		
Heater Indicator:	No Heater		
Insulation Class:	F		
Lifting Lugs:	Standard Lifting Lugs		
Mounting Arrangement:	F1		
Shaft Extension Location:	Pulley End		

Shaft Ground Indicator:	No Shaft Grounding		
Shaft Slinger Indicator:	No Slinger		
Motor Standards:	NEMA		
Thermal Device - Bearing:	None		

Nameplate 000613006LP	
CAT.NO.	D5015RS-BV
FR	SC 2113ATZ
ENCL.	DP
ENCL MOD	FORCE VENT
MAX SAFE SPEED	4500
FIELD DATA	
WINDING	STAB SHUNT
VOLTS	300
MAX AMPS @ 25 C	3.04
HOT AMPS	2.13/ 1.42
BRUSH:419904051AB; AIR BAFFLED	
SPEC NO.	T21T1346
HP	15
RPM	1750/ 2300
VOLTS	500
AMPS	27.00
SER.NO.	
DUTY	CONT
S.F.	1.0
INSUL	F
AMB.	40
POWER CODE	C
D.E. BRG.	50BC03J30X
O.D.E. BRG.	45BC02J30X
MIN. AMB.	0
TYPE	TR

Parts List		
Part Number	Description	Quantity
SA297137	SA T21T1346	1.000 EA
AA016165	AA T21T1346	1.000 EA
000613006LP	EXTRUDER DUTY D-C MOTOR W/CSA	1.000 EA
000692000FP	NP, WARNING LIFT INSTRUCTIONS	1.000 EA
000692000FS	WARNING LABEL	1.000 EA
036170004EA	ROUND HEAD DRIVE SCREW	6.000 EA
406770001	C/D TAG (STAB SHUNT)	1.000 EA
036000012HB	HHCS M6X12MM LONG PLATED	4.000 EA
036000020KB	MHHCS M10-1.5X20MM PLTD.	4.000 EA
036501008AB	KPNUT M6-1.0 ZINCPLETED	8.000 EA
036610010AB	MHSLW M10 PLATED	4.000 EA
419904051AB	BRUSH EXTRUDER DUTY C	4.000 EA
419905003A	FLAT WASHER ROCKER RPM III RGG	4.000 EA
419905008A	HARDWARE	8.000 EA
706364051AA	BRHLD ADD HARDWARE	4.000 EA
706372001B	ROCKR METRIC	1.000 EA
034693001AB	PPLG - G508- use 034692001AB	1.000 EA
034693001AB	PPLG - G508- use 034692001AB	1.000 EA
035000001A	ALFTG 1/8" 1610-BL	1.000 EA
035000001BB	GREASE FTG,GRS.IN	1.000 EA
036000055JB	HHCS,DE CAP	2.000 EA
036000060KB	HHCS,DE CAP	3.000 EA
036310012FB	PHMS M4 X 12MM M2	6.000 EA
036500010AB	METRIC NUT M10-1.5PLTD400	4.000 EA

Parts List (continued)		
Part Number	Description	Quantity
036500010AB	METRIC NUT M10-1.5PLTD400	4.000 EA
036501006AB	KPNUT M4 ZINC	6.000 EA
048977006B	GRFTG - XP	1.000 EA
400638001H	SPRING WASHER (Customer number 43699)	1.000 EA
412118001B	3/8-16 X 3/4 DRAIN SSTL.	1.000 EA
418057013A	GROMT	2.000 EA
418150003A	GREASE FITTING CAP	2.000 EA
609830005M	TBOLT METRIC RP609830-	4.000 EA
706311004E	PLATE	1.000 EA
706311004F	BAFFLE CX NOMEX .24 MI	1.000 EA
706311004X	BAFLE	1.000 EA
801924102A	BRKT,ODE,C210	1.000 EA
801925114Y	BRKT,DE,C210	1.000 EA
000613006NT	NAME PLATE IEC	1.000 EA
032018004CK	HHCS 3/8-16X1/2L PLATED	4.000 EA
032018006CK	HHCS 3/8-16X3/4L PLATED	4.000 EA
034017014AB	LCKW 3/8 STD. PLATED	4.000 EA
036000012HB	HHCS M6X12MM LONG PLATED	2.000 EA
036000012JB	M8-1.25 X 12MM HXHDC	3.000 EA
036000020JB	HHCS M8-1.25X20L PLTD-250	4.000 EA
036000020JB	HHCS M8-1.25X20L PLTD-250	4.000 EA
036000025JB	HHCS M8X25MM LONG PLATED	2.000 EA
036000045HB	MHHCS M6X45MM PLATED	3.000 EA
036000045JB	M8-1.25 X 45MM HXHCS	4.000 EA

Product Information Packet: D5015RS-BV - 15HP,1750RPM,DC,2113ATZ,DPG-FV,

036010012GB	M5-.8 X 12 HXWHD SCREW	6.000 EA
036100012JA	M8-1.25 X 12 MMHXSOCHDCS	2.000 EA
036100012JB	HSHCS BRKT CVR	2.000 EA
036600008AB	MFWSH M6 PLATED	3.000 EA
036600009AB	METRIC FLWASH M8 PLATED	3.000 EA
036620009AB	M8 EXTERNAL LK WASHER	1.000 EA
065564000B	GASK 250-280	1.000 EA
075453000A	CBOXC, PAINTED 250-280	1.000 EA
410978010C	FLANGE, INLET BLOWER HSG.	1.000 EA
410978019A	SCREEN, INLET FLANGE	1.000 EA
417077121	FILTER KIT	1.000 EA
417733001D	GASKT	2.000 EA
418010006A	CAST,MPLATE,180-280,EX1,7BY	1.000 EA
418018070A	TAG "WARNING THERMOSTA	1.000 EA
418018074A	GROUND LABEL G100 METRIC 160 D.C.	1.000 EA
422919001	CVRKT BE SOLID C210	1.000 EA
422919001	CVRKT BE SOLID C210	1.000 EA
422919001	CVRKT BE SOLID C210	1.000 EA
422919012	HHCVR KIT,C210,ODE,SOLID	1.000 EA
422919012	HHCVR KIT,C210,ODE,SOLID	1.000 EA
422919023	HHCVR KIT, C250,ODE LEXAN	1.000 EA
610409050A	ADAPTER DYE	1.000 EA
610490001AH	.75HP,3450//2850RPM,3PH,60//50HZ,56C,351	1.000 EA
611917001B	GASKT	1.000 EA
611917002A	GASKT	1.000 EA
611917002B	GASKT	1.000 EA

Product Information Packet: D5015RS-BV - 15HP,1750RPM,DC,2113ATZ,DPG-FV,

611965001A	WHEEL, BLOWER	1.000 EA
705034033A	BAFFL	1.000 EA
706303018A	GUARD	2.000 EA
706303018B	GUARD	2.000 EA
706305026A	GUARD,SHAFT	1.000 EA
706320005A	CONDUIT BOX	1.000 EA
708528004G	HOUSING, BLOWER	1.000 EA
000640000P	TAG WINDING THERMOST	1.000 EA
000692000NG	LABEL ;NP 4POLE METRIC LABEL	1.000 EA
034180020GA	KEY 1/2X1/2X2-1/2 L	1.000 EA
418018116	WARNING PLATE	1.000 EA

609952-096

INDUSTRIAL DIRECT CURRENT MOTORS AND GENERATORS - RPM III

ENCLOSURE: DRIP-PROOF FULLY-GUARDED, SPLASHPROOF
 COOLING: FORCE VENTILATED WITH INTEGRAL BLOWER AND MOTOR WITH AIR FILTERED-SPECIAL BAFFLE
 MOUNTING: FOOT
 METHOD OF DRIVE: COUPLED OR BELTED
 FRAMES SC2113ATZ THRU C2813ATZ
 ACCESSORIES: PROVISION FOR TACHOMETER MOUNTING ONLY WHEN SPECIFIED

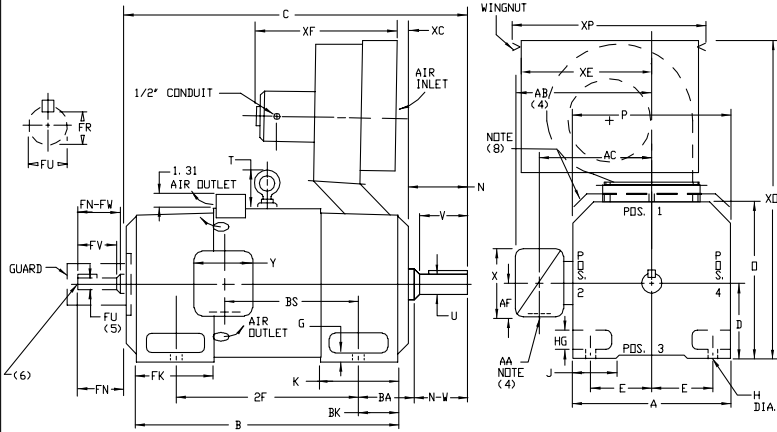

DIMENSIONS ARE IN INCHES

FRAME	MC	ME	MF	XD	XP
SC2113ATZ-LC2113ATZ	1.00	10.00	17.25	28.00	14.50
SC2512ATZ-LC2512ATZ	2.50	10.00	17.25	30.31	14.50
MC2812ATZ-LC2813ATZ	1.75	10.00	18.50	30.62	14.50

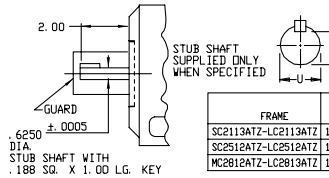

FRAME	A	D(1)	E	G	H	HG	J	D	P	T	BA	K	FK	BK
SC2113ATZ-LC2113ATZ	10.25	5.25	4.25	.44	1.38	1.75	10.44	10.31	2.56	3.50	5.19	6.81	2.38	3.00
SC2512ATZ-LC2512ATZ	12.31	6.25	5.00	.56	1.62	2.00	12.50	12.44	3.06	4.25	6.06	8.00	3.00	3.00
MC2812ATZ-LC2813ATZ	13.78	7.00	5.50	.62	1.56	1.88	14.00	13.94	3.38	4.75	6.75	9.19	3.50	3.50

FRAME	C	B	BS	2F	DRIVE END SHAFT AND KEY										OPPOSITE DRIVE END SHAFT AND KEY(S)					WT. LBS.
					N	N-V	U(2)	V	R(3)	SO	LGTH	FN	FN-FW	FU(2)	FV	FR(3)	SD	LGTH		
SC2113ATZ	28.38	22.50	11.38	18.00	4.00	3.75	1.875	3.50	1.591	500	2.50	3.50	3.25	1.625	3.00	1.416	375	2.25	345	
MC2113ATZ	29.62	23.75	12.62	18.00	4.00	3.75	1.875	3.50	1.591	500	2.50	3.50	3.25	1.625	3.00	1.416	375	2.25	370	
LC2113ATZ	31.25	25.38	14.25	18.00	4.00	3.75	1.875	3.50	1.591	500	2.50	3.50	3.25	1.625	3.00	1.416	375	2.25	400	
SC2512ATZ	31.69	25.06	12.06	20.00	4.50	4.25	2.125	4.00	1.845	500	3.00	4.00	3.75	1.875	3.50	1.591	500	2.50	535	
MC2512ATZ	33.19	26.56	13.56	20.00	4.50	4.25	2.125	4.00	1.845	500	3.00	4.00	3.75	1.875	3.50	1.591	500	2.50	570	
LC2512ATZ	34.69	28.06	15.06	20.00	4.50	4.25	2.125	4.00	1.845	500	3.00	4.00	3.75	1.875	3.50	1.591	500	2.50	610	
MC2812ATZ	37.38	29.94	14.25	22.00	5.00	4.75	2.375	4.50	2.021	625	3.50	4.50	4.25	2.125	4.00	1.845	500	3.00	810	
LC2812ATZ	39.62	32.19	16.50	22.00	5.00	4.75	2.375	4.50	2.021	625	3.50	4.50	4.25	2.125	4.00	1.845	500	3.00	885	
LC2813ATZ	41.25	33.81	18.12	25.00	5.00	4.75	2.375	4.50	2.021	625	3.50	4.50	4.25	2.125	4.00	1.845	500	3.00	940	

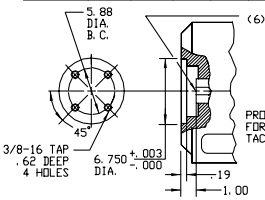

- (1) "B" DIMENSION WILL NOT BE EXCEEDED. SHIMS UP TO .03 INCHES IN THICKNESS ARE USUALLY REQUIRED FOR COUPLED OR GEARED MACHINES.
 - (2) "U" AND "FU" VARY-----+.000 - .001.
 - (3) "R" AND "FR" VARY-----+.000 - .015.
 - (4) TERMINAL BOX VARIES WITH H.P. FOR DIMENSIONS "AA", "AB", "AC", "AF", "X" AND "Y". REFER TO BOX D/S. (STD. 609959-1, "X/P" 609959-2, MILL 609959-3).
 - (5) OPPOSITE DRIVE END SHAFT SUPPLIED ONLY WHEN SPECIFIED.
 - (6) MOTOR SHAFT TAPPED FOR SCREW-IN STUB SHAFT.
 - (7) WHEN THE MOTOR APPLICATION DOES NOT REQUIRE THE USE OF DRP, DRIVE END, ADD .25 TO "C" DIM. FOR BRACKET COVER.
 - (8) FOR HORIZONTAL APPLICATIONS ONLY.
- TERMINAL BOX CAN BE ROTATED FOR LEAD OUTLET AT TOP, SIDES OR BOTTOM. TERMINAL BOX LOCATED ON OPPOSITE SIDE WHEN F-2, W-1, V-4, W-5, W-7, OR C-1 MOUNTING IS SPECIFIED. BOX LOCATED ON TOP WHEN SPECIFIED. BLOWER ASSEMBLY CAN BE LOCATED AT POSITIONS 1, 2, OR 4. MOTOR WEIGHT MAY VARY 15% FOR NON-STANDARD RATINGS AND/OR ACCESSORIES. IF MOUNTING CLEARANCE DETAILS ARE REQUIRED, CONSULT FACTORY. BLOWER MOTOR

CUSTOMER IS RESPONSIBLE FOR DETERMINING THAT BALDOR'S PRODUCT WILL PERFORM SUITABLY IN THE INTENDED APPLICATION.

REV. DESC: UPDATE FRAME SIZE	VERSION: 01	TDR: 000000845571
REV. LTR: A	REVISED: 10:46:47 03/25/2014	BY: RGGWT
FILE: \RGG\00015\585		
MTL: -		

BALDOR

DIMENSION DRAWING, SC2113ATZ - C2813ATZ, DPP, FOOT MTG.

SH 1 of 1

609952-096

609959-001

**INDUSTRIAL DIRECT CURRENT MOTORS
AND GENERATORS - RPM III**
TERMINAL BOX DIMENSIONS
STANDARD SIZE AND ONE SIZE LARGER
FRAMES C2113ATZ THRU C2815ATZ

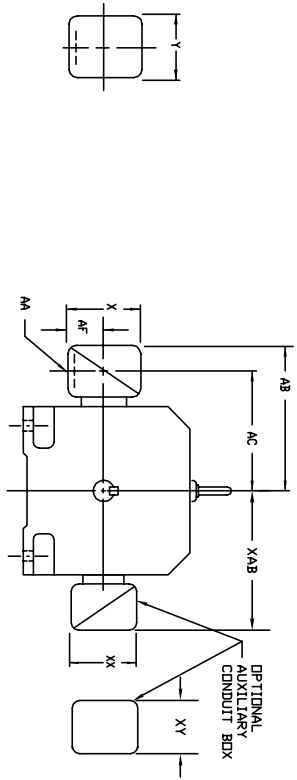

FRAME SIZE	STANDARD SIZE						ONE SIZE LARGER								
	MAX. AMPS	AK(1)	AB	AC	AF	PART NUMBER	AK(1)	AB	AC	AF	PART NUMBER				
C2113ATZ	40	3/4 & 1"	8.97	7.47	1.94	4.38	5.00	7.05028-1-R	1-1/4 & 1-1/2	10.03	8.03	2.50	5.00	6.12	7.05029-1-R
C2115ATZ	96	1-1/4 & 1-1/2	10.03	8.03	2.50	5.00	6.12	7.05029-1-R	2" & 2-1/2	11.16	8.41	3.19	7.00	7.62	7.05030-1-R
C215ATZ	208	2" & 2-1/2	11.16	8.41	3.19	7.00	7.62	7.05030-1-R	2" & 2-1/2	11.16	8.41	3.19	7.00	7.62	7.05030-1-R
C2513ATZ	40	3/4 & 1"	10.03	8.53	1.94	4.38	5.00	7.05029-1-R	1-1/4 & 1-1/2	11.09	9.09	2.50	5.00	6.12	7.05029-1-R
C2515ATZ	96	1-1/4 & 1-1/2	11.09	9.09	2.50	5.00	6.12	7.05029-1-R	2" & 2-1/2	12.22	9.47	3.19	7.00	7.62	7.05030-1-R
C2515ATZ (2)	208	2" & 2-1/2	12.22	9.47	3.19	7.00	7.62	7.05030-1-R	2" & 2-1/2	12.22	9.47	3.19	7.00	7.62	7.05030-1-R
C2813ATZ	128	2"	14.03	10.53	4.25	8.44	7.25	7.4874-R	3"	14.47	11.22	4.25	8.44	7.25	7.4874-R
C2815ATZ	185	3"	14.47	11.22	4.25	8.44	7.25	7.4874-R	4"	15.91	11.84	5.38	10.56	9.00	7.0308-3-R
C2815ATZ	259	4"	15.91	11.84	5.38	10.56	9.00	7.0308-3-R	5" (4)	18.72	13.47	7.00	12.75	15.00	7.02658-1-C

FRAME SIZE	STANDARD SIZE						ONE SIZE LARGER								
	MAX. AMPS	AK(3)	AB	AC	AF	PART NUMBER	AK(3)	AB	AC	AF	PART NUMBER				
C2113ATZ	18	3/4	10.03	8.03	2.50	5.00	5.75	7.05028-2-S	1"	10.03	8.03	2.50	5.00	5.75	7.05028-2-T
C2115ATZ	40	1"	10.03	8.03	2.50	5.00	5.75	7.05028-2-R	1-1/2	10.97	8.53	3.00	6.00	7.00	7.05029-2-S
C215ATZ	96	1-1/2	10.97	8.53	3.00	6.00	7.00	7.05029-2-R	2"	10.97	8.53	3.00	6.00	7.00	7.05029-2-S
C2513ATZ	18	3/4	10.97	8.53	3.00	6.00	7.00	7.05029-2-S	1"	11.09	9.09	2.50	5.00	5.75	7.05028-2-T
C2515ATZ	40	1"	11.09	9.09	2.50	5.00	5.75	7.05028-2-T	1-1/2	12.03	9.59	3.00	6.00	7.00	7.05029-2-R
C2515ATZ	96	1-1/2	12.03	9.59	3.00	6.00	7.00	7.05029-2-S	2"	12.03	9.59	3.00	6.00	7.00	7.05029-2-S
C2813ATZ	128	2"	12.03	9.59	3.00	6.00	7.00	7.05029-2-S	1-1/2	12.03	9.59	3.00	6.00	7.00	7.05029-2-R
C2815ATZ	185	3"	14.47	10.72	3.62	7.88	7.88	7.88	7.88	14.47	10.72	3.62	7.88	7.88	7.88
C2815ATZ	259	4"	15.78	11.59	4.12	9.34	7.00	12.75	15.00	18.59	13.34	7.00	12.75	15.00	7.02658-1-S

FRAME SIZE	STANDARD SIZE						ONE SIZE LARGER					
	AMP(S)	AB	AC	AF	X	Y	AB	AC	AF	X	Y	
C210	100	10.71	8.98	2.72	7.48	7.48	7.48	7.48	7.48	7.48	7.48	
	200	11.26	9.25	3.35	8.82	8.82	8.82	8.82	8.82	8.82	8.82	
	100	11.30	9.57	2.72	7.48	7.48	7.48	7.48	7.48	7.48	7.48	
	200	11.85	9.84	3.35	8.82	8.82	8.82	8.82	8.82	8.82	8.82	
C290	400	17.48	12.75	6.20	14.39	14.39	14.39	14.39	14.39	14.39	14.39	
	800	17.48	12.75	6.20	14.39	14.39	14.39	14.39	14.39	14.39	14.39	
	200	12.60	10.99	3.76	8.82	8.82	8.82	8.82	8.82	8.82	8.82	
	400	18.27	13.54	6.20	14.39	14.39	14.39	14.39	14.39	14.39	14.39	
	800	18.27	13.54	6.20	14.39	14.39	14.39	14.39	14.39	14.39	14.39	
C280	1600	18.27	13.54	7.68	15.35	15.35	15.35	15.35	15.35	15.35	15.35	

FRAME SIZE	OPTIONAL AUXILIARY CONDUIT BOX DIMENSIONS (MAXIMUM)					
	XAB	XX	XY	Y	XY	XY
C210	7.38	4.25	4.25	6.02007-26-A	C210	10.88
C250	8.44	4.25	4.25	6.02007-26-A	C250	11.88
C280	9.12	4.25	4.25	6.02007-26-A	C280	12.62

(1) *AM. CONDUIT
(2) STEEL TERMINAL BOX FOR C2113ATZ AND C2515ATZ
(3) *AM. PIPE TAP
(4) TERMINAL BOX 76870-9R EXTENDS BELOW MOTOR FEET.
TERMINAL BOX CAN BE ROTATED FOR LEAD OFFSET AT TOP, SIDES OR BOTTOM.
TERMINAL BOX LOCATED ON OPPOSITE SIDE WHEN F-2, V-1, V-4, V-5, V-7,
OR C-1 MOUNTING IS SPECIFIED. BOX LOCATED ON TOP WHEN SPECIFIED.
FOR *X/P TERMINAL BOX DIMENSIONS SEE 609959-2.
FOR **X/P TERMINAL BOX DIMENSIONS SEE 609959-3.

CUSTOMER IS RESPONSIBLE FOR DETERMINING THAT BALDOR'S PRODUCT WILL PERFORM SUITABLY IN THE INTENDED APPLICATION.

REV. DESC: ADD 706310-63G C/BOX TO C250 AND C280 FRAMES	VERSION: 01	TDR: 000000816512
REV. LTR: A		
FILE: \RGG\00021\153		REVISED: 03:09:09 09/06/2013
MTL: -		BY: RGGWT



DIMENSION SHEET
SH 1 of 1

609959-001

406770-001

406770-001

**CONNECTION DIAGRAM
D-C MOTOR - STAB. SHUNT**

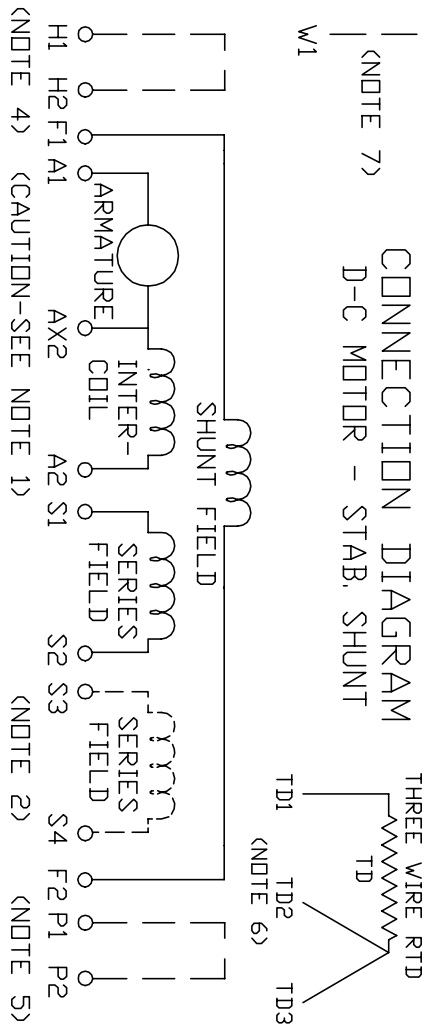

ARMATURE AND FIELD EXTERNAL CONNECTIONS
WARNING- SEE NOTE 8 FOR GROUNDING INSTRUCTIONS



ROTATION FACING COMMUTATOR END

- CAUTION** — ARMATURE AND SERIES FIELD MAY HAVE MULTIPLE LEADS. CONNECT ALL LUGS WITH THE SAME MARKING TOGETHER.
 - OPTIONAL SERIES FIELD IS MARKED S3 AND S4. FOR CUMULATIVE SERIES FIELD, CONNECT S3 TO S2 AND CONNECT S4 TO NEGATIVE. FOR DIFFERENTIAL SERIES FIELD CONNECT S4 TO S2 AND S3 TO NEGATIVE.
 - OPTIONAL CONTROL SIGNAL LEAD IS MARKED AX2. ALWAYS TAKE INTERPOLE DROP BETWEEN A2 AND AX2. NOTE: NEMA DESIGNATION FOR AX2 IS LETTER C.
 - SPACE HEATERS, WHEN PROVIDED, WILL HAVE LEADS MARKED H1 AND H2, H3, H4, ETC.
 - THERMAL PROTECTOR, WHEN PROVIDED, WILL HAVE LEADS MARKED P1 AND P2, P3, P4, ETC.
 - WINDING RTD'S, WHEN PROVIDED, WILL HAVE LEADS MARKED TD1, TD2, & TD3
 - BRUSH WEAR SENSOR, WHEN PROVIDED, WILL HAVE LEAD MARKED W1.
 - WARNING** — MOTOR MUST BE GROUNDED TO PREVENT SERIOUS INJURIES TO PERSONNEL. GROUND THE MOTOR PER IEC, NATIONAL ELECTRICAL CODE AND ANY APPLICABLE LOCAL ELECTRICAL CODES. A TAPPED HOLE IS PROVIDED IN THE CONDUIT BOX, ON THE FOOT. FRAME BRACE OR OPPOSITE DRIVE END BRACKET, ADJACENT TO THE TERMINAL BOX FOR MOTOR GROUNDING. GROUND LEAD, WHEN PROVIDED, WILL BE GREEN.
- CUSTOMER _____ RELIANCE
ORDER NO. _____ S.D. NO. _____

REV. DESC: DELETED DUPLICATE WORDS FROM NOTE 8		
REV. LTR: A	VERSION: 01	TDR: 000000970330
FILE: \RSN\00026\422	REVISED: 10:19:12 03/11/2016	BY: RAGTBM
MTL: -		

BALDOR

D-C MOTOR CONNECTION DIAGRAM STAB. SHUNT

SH 1 of 1

Marketing maintained PDF of MN602:

<http://www.baldor.com/support/Literature/Load.ashx/MN602?ManNumber=MN602>